

TABLE OF CONTENTS:

- SHEET 1- TABLE OF CONTENTS, GENERAL NOTES, ALLOWABLE PRESSURE TABLE 1, DESIGN SCHEDULE
- SHEET 2- TYPICAL ELEVATIONS AND MOUNT OPTIONS
- SHEET 3- PRODUCT COMPONENTS AND SLAT END RETENTION LAY-OUT
- SHEET 4- TYPICAL VERTICAL SECTIONS EE & DD, TABLE A1 WALL MOUNT TRACK ANCHORAGE
- SHEET 5- TABLE A2 AND A2.1 INSET MOUNT TRACK ANCHORAGE WITH ONE OR TWO TUBES
- SHEET 6- TABLE A3 AND A3.1 BUILT-OUT MOUNT TRACK ANCHORAGE WITH 2X3 AND 3X3 TUBES
- SHEET 7- EQUAL SPACED MULLION SELECTION TABLE
- SHEET 8- EQUALLY SPACED MULLIONS WALL AND INSET CONNECTIONS
- SHEET 9- HOOD ASSEMBLY

GENERAL NOTES: (FLORIDA BUILDING CODE 2023 8th EDITION - HVHZ)

- 1- DEFINITION: THIS PRODUCT IS A ROLLING TYPE DOOR; DESIGNED, CONSTRUCTED AND ERECTED TO EASILY ENCLOSE AN AREA, PROVIDING PROTECTION FROM HURRICANE FORCE WINDS WITHIN THE ALLOWABLE DESIGNED PRESSURES AND LIMITATIONS STATED IN THIS APPROVAL.
- 2- CODE: THIS PRODUCT HAS BEEN TESTED AND DESIGNED IN ACCORDANCE WITH THE FLORIDA BUILDING CODE 2023 - 8TH EDITION UNDER THE TAS 201, TAS 202, TAS 203, ASTM E330, ASTM E1886, ASTM E1996.
- 3- POSTING: A PERMANENT LABEL SHALL BE PROVIDED AS PER FBC AND IT SHALL BE LOCATED ON THE BOTTOM OF THE HOOD FACING THE EXTERIOR OR OUTSIDE AND A MINIMUM OF ONE LABEL PER OPENING.
- 4- LOADS: DESIGNED LOAD CALCULATED BASED ON THE ASCE 7-22 AND PROVIDED BY A PROFESSIONAL ARCHITECT OR ENGINEER FOR EACH SPECIFIC PROJECT. THE CALCULATED DESIGNED PRESSURE MUST NOT EXCEED THE ALLOWABLE PRESSURES FOR EACH DOOR COMPONENT TO BE USED. THE ULTIMATE DESIGN PRESSURES ARE PERMITTED TO BE MULTIPLIED BY 0.6
- 5- MATERIAL: ALL EXTRUDED ALUMINUM SHAPES SHALL BE MADE OF 6063-T6 OR AS NOTED.
- 6- FASTENERS: ASSEMBLY SCREWS AND ANCHORS SHALL BE AS SPECIFIED IN THE CURRENT SET OF DRAWINGS. INSTALLATION AND LOADS AS PER THIS APPROVAL.
- 7- USE: IT SHALL BE THE RESPONSIBILITY OF THE CONTRACTOR, ARCHITECT OR ENGINEER OF RECORD TO VERIFY THE FOLLOWING:
 - 7.1- THE STABILITY OF THE STRUCTURE WHERE THE DOOR IS TO BE ATTACHED INSURING PROPER ANCHORAGE.
 - 7.2- THE SITE SPECIFIC PROJECT CRITERIA, SUCH AS BUT NOT LIMITED TO, WIND LOADS, LOCAL CODE REQUIREMENTS, DESIGNED PRESSURES ETC.
 - 7.3- THAT THIS APPROVAL IS ADEQUATE TO THE SPECIFIC PROJECT.
- 8- DISCLAIMER: PPMF INC. HAS NO CONTROL IN THE MANUFACTURING AND/OR PERFORMANCE OF THIS PRODUCT. THESE GENERIC PLANS WERE ENGINEERED IN ACCORDANCE WITH ACCEPTED ENGINEERING PRACTICES AND TEST DATA PROVIDED BY THE MANUFACTURER.
- 9- THE ROLL-UP MECHANISM (GEARS, MOTORS, SUPPORTING END PLATES) ARE NOT PART OF THIS APPROVAL. MANUFACTURER ARE RESPONSIBLE TO SPECIFY THESE COMPONENTS FOR PROPER DOOR OPERATION.
- 10- LIMITATIONS: PRODUCT MUST BE INSTALLED OFFSET FROM GLAZING PRODUCTS AS INDICATED PER TABLE 1.

CODE AND STANDARD COMPLIANCE:
 FLORIDA BUILDING CODE 2023 - 8TH EDITION
 (HVHZ & non HVHZ)
 TAS 201, TAS 202, TAS 203 - (LARGE MISSILE)
 ASTM E330, E1996, E1886 (LEVEL D MISSILE)
 ASCE 7-22, ADM-20, NDS 2018

DESIGN SCHEDULE	
COMPONENT	SHEET
SLAT ALLOWABLE PRESSURE - TABLE 1	1
TRACK ANCHORAGE	4 & 5
EQUALLY SPACED MULLIONS	6 & 7
UNEQUALLY SPACED AND END MULLIONS	8 & 9

- NOTES:
- 1-ALLOWABLE DESIGNED PRESSURE FOR MULTIPLE DOORS ARE FUNCTION OF THE LOWEST ALLOWABLE DESIGNED LOAD FOR THE SLATS, MULLIONS AND ANCHORAGE.
 - 2- DESIGNED PRESSURES MUST NOT EXCEED 110 PSF.
 - 3- DOOR SIZE (TT) MUST NOT EXCEED 120".
 - 4- FOR MULTIPLE DOORS USE TABLE 1 TO VERIFY MAXIMUM ALLOWABLE PRESSURE THAN USE TABLE 2 AND 3 TO SELECT INTERMEDIATE AND END MULLIONS AND SELECT PROPER MULLION ANCHORAGE

TABLE 1 - ALLOWABLE DESIGNED PRESSURE

FW MAX.	ALLOWABLE WIND PRESSURES		GLASS SEPARATION GS MIN.(IN)
	POSITIVE	NEGATIVE	
124"	+ 40.0	- 40.0	14"
109"	+ 50.0	- 50.0	9"
94"	+ 60.0	- 60.0	6"
82"	+ 80.0	- 80.0	6"
64"	+110.0	-110.0	6"

GLASS SEPARATION (GS):

PRODUCT IS QUALIFIED AS "NON POROUS", THEREFORE GLAZING SEPARATION IS NOT REQUIRED WITH EXCEPTION FOR THE FOLLOWING LOCATIONS:

- 1- HIGH VELOCITY HURRICANE ZONES (HVHZ MIAMI-DADE & BROWARD COUNTIES)
- 2- WIND ZONE 4 AS DEFINED IN ASTM E 1996
- 3- ESSENTIAL FACILITIES AS DEFINED IN ASCE 7

TRACK REACTION (LB/FT)

LOAD Psf	FINISHED WIDTH (FW)									
	64		82		94		109		124	
	Vx	Vy	Vx	Vy	Vx	Vy	Vx	Vy	Vx	Vy
30	62	74	359	96	540	111	443	130	361	149
40	149	99	496	129	712	149	516	174	397	199
45	187	111	557	145	789	167	545	195		
50	220	123	614	161	862	186	571	217		
55	251	135	667	177	930	204				
60	280	148	716	193	993	223				
65	306	160	763	209						
70	330	172	807	225						
80	373	197	887	257						
90	410	222								
100	442	246								
105	457	259								
110	471	271								

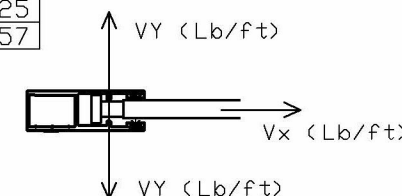

CONTRACTOR TO VERIFY ADEQUACY OF STRUCTURE FOR MAXIMUM IMPOSED LOADS VY AND Vx

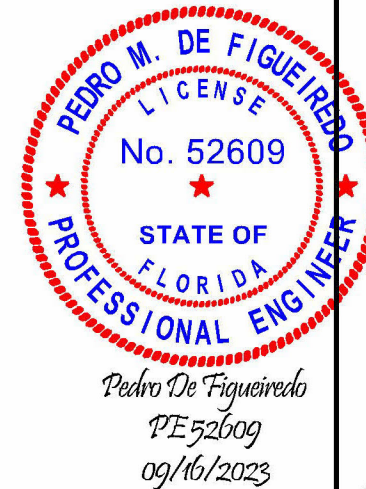

ENGINEERING SERVICES
 CA 32459
 9715 W. BROWARD BLVD. 247
 PLANTATION, FL 33324
 PPMF@AOL.COM
 ENGINEER SEAL
 PEDRO DE FIGUEIREDO
 PE 52609



DIGITALLY SIGNED FOR 10 PAGES

THIS DOCUMENT HAS BEEN DIGITALLY SIGNED AND SEALED BY PEDRO DE FIGUEIREDO, PE 52609 ON THE DATE INDICATED HERE.

PRODUCT:
 E544 SUP
 ROLLING DOOR
 LARGE & SMALL MISSILE
 IMPACT RATED

MANUFACTURER:
CROCI
 NORTH AMERICA
 11600 ADELMO LANE FORT MYERS, FL 33966
 TEL.: (239) 278-3066 - FAX: (239) 278-5977
 EMAIL: INFO@CROCIUSA.COM

SCALE:
 NA

DATE:
 09/16/2023

DRAWING #
 23-164

SHEET
 1 of 10

PRODUCT COMPONENTS

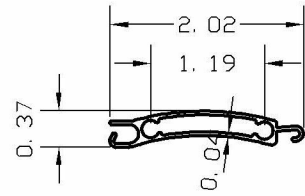

A- ES44SUP SLAT
6063-T5 EXTRUDED ALUMINUM

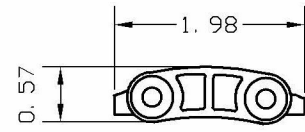

A1- SLAT NYLON RETAINER
SECURED TO SLAT BY
(2) #10X1 1/2" PFH SMS

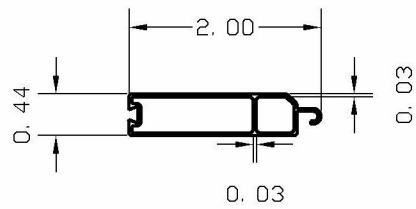

B- TE7X56U END SLAT
6063-T6 EXTRUDED ALUMINUM

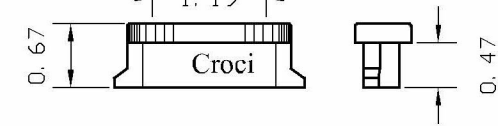

D- SLAT RETENTION SCREW
#10x1-1/2" 18-8 SS PFH
SHEET METAL SCREW

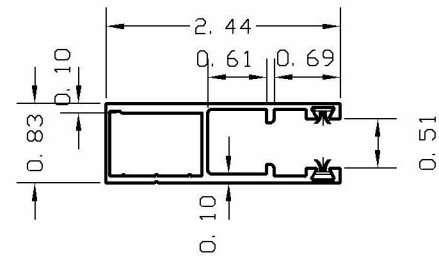

C- GE62X21SUP GUIDE RAIL W/ FELT
6063-T5 EXTRUDED ALUMINUM

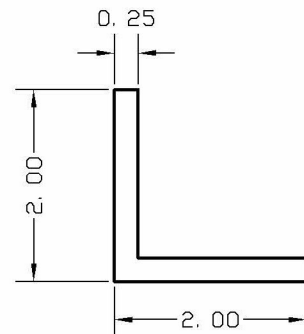

E- INSET SUPPORT ANGLE
EXTRUDED ALUMINUM
6061-T6 or 6005-T5

TYPICAL SINGLE UNIT ELEVATION

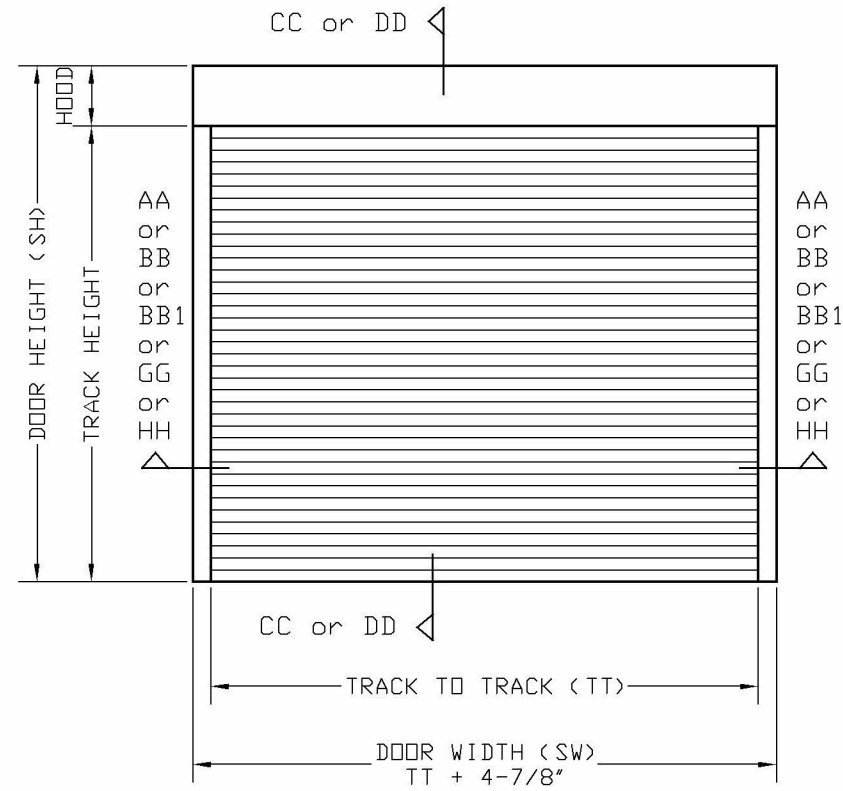

TYPICAL MULTIPLE UNITS ELEVATION

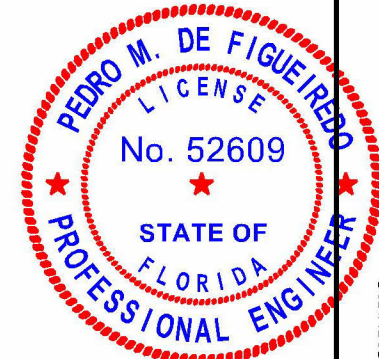
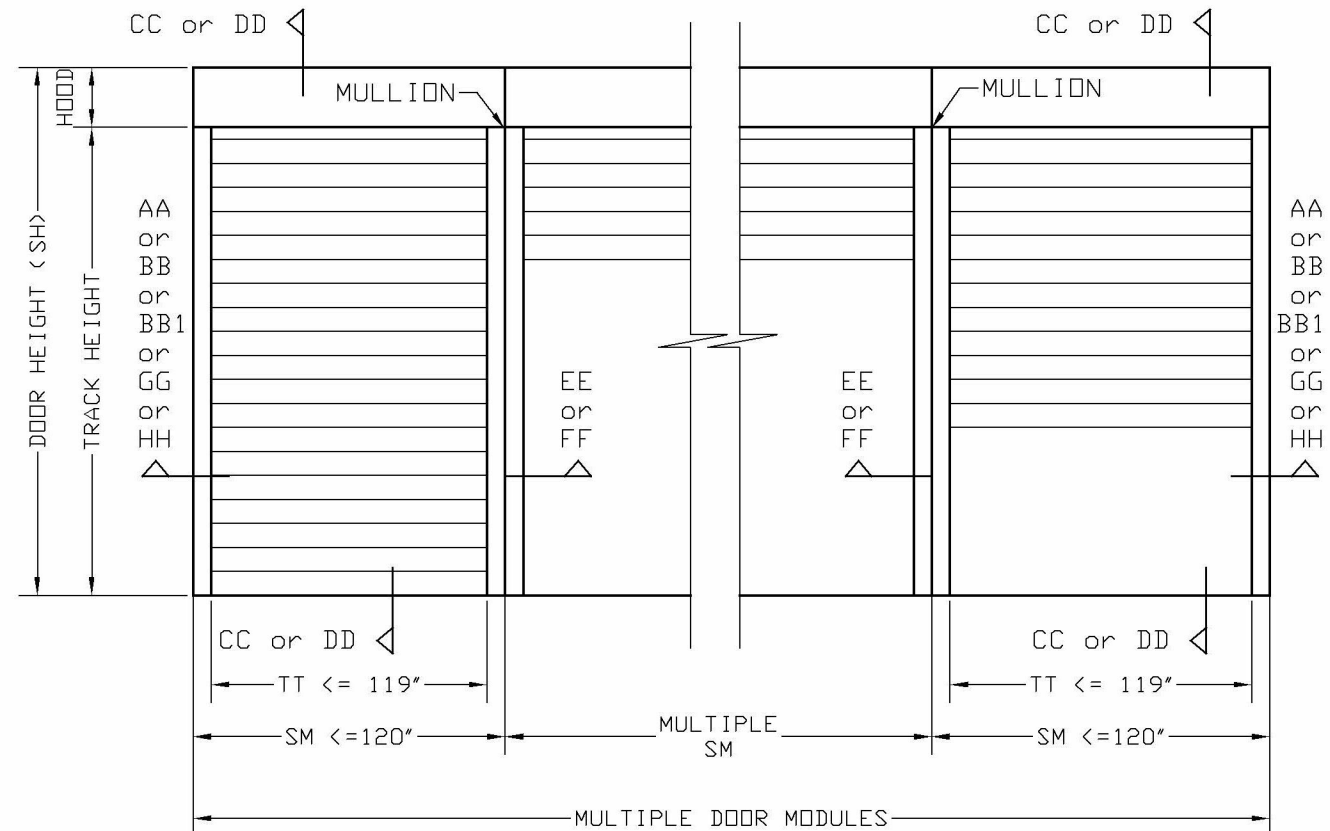

Pedro De Figueiredo
PE 52609
09/16/2023

THIS ITEM HAS BEEN DIGITALLY SIGNED AND SEALED BY
PEDRO DE FIGUEIREDO ON THE DATE INDICATED HERE.



ENGINEERING SERVICES
CA 32459

9715 W. BROWARD BLVD. 247
PLANTATION, FL 33324
PFMIF@AOL.COM

ENGINEER SEAL
PEDRO DE FIGUEIREDO
PE 52609

PRODUCT:
ES44 SUP
ROLLING DOOR
LARGE & SMALL MISSILE
IMPACT RATED

MANUFACTURER:
CROCI
NORTH AMERICA
11600 ADELMO LANE FORT MYERS, FL 33966
TEL: (239) 278-3066 - FAX: (239) 278-5977
EMAIL: INFO@CROCIUSA.COM

SCALE:
NA

DATE:
09/16/2023

DRAWING #
23-164

SHEET
2 of 10

TYPICAL VERTICAL SECTIONS

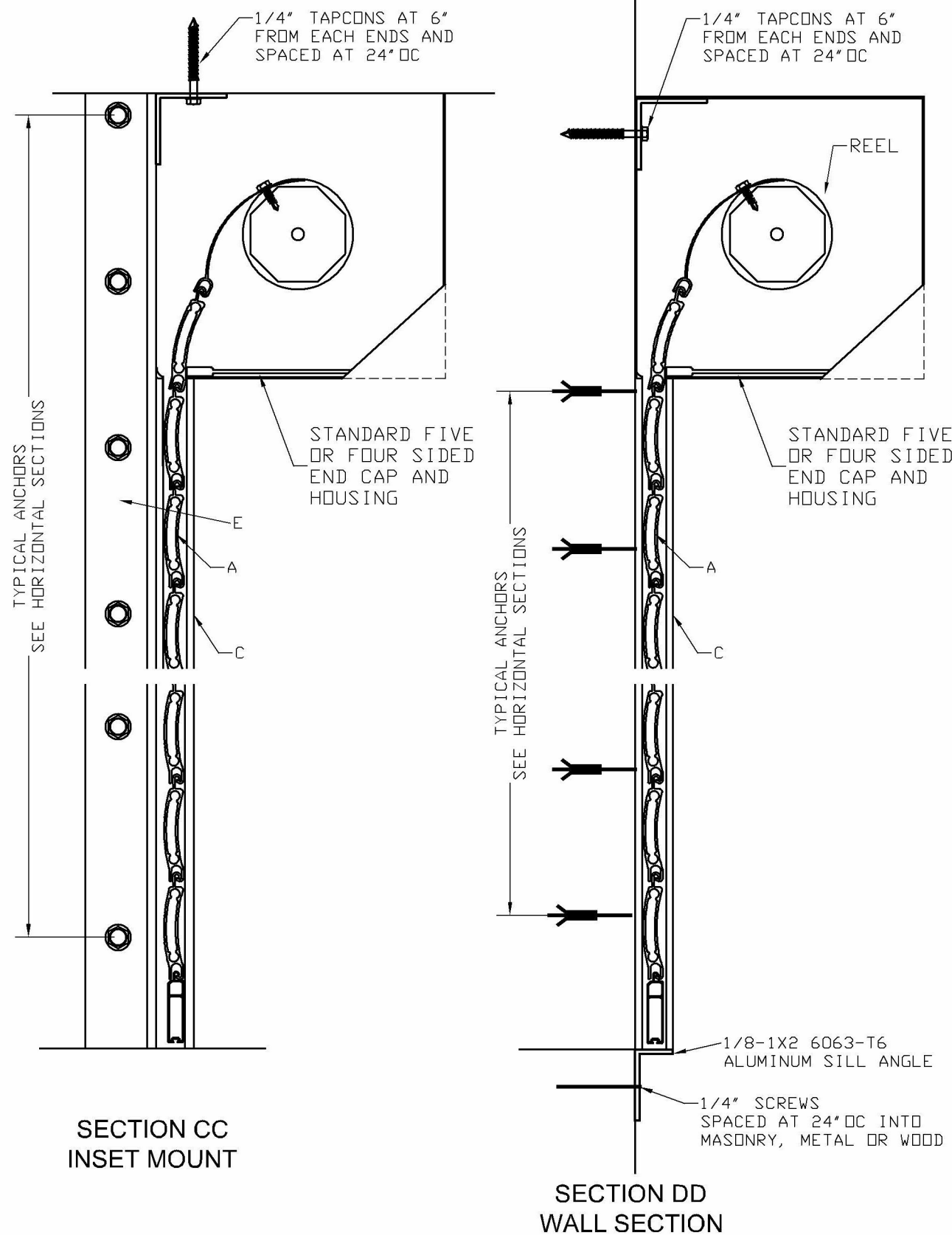

SLAT END RETENTION LAY-OUT

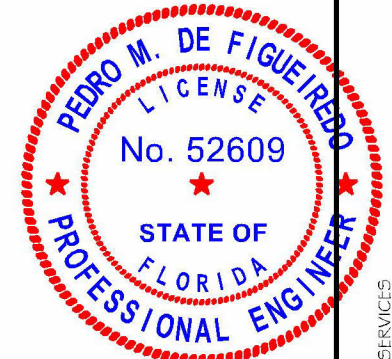
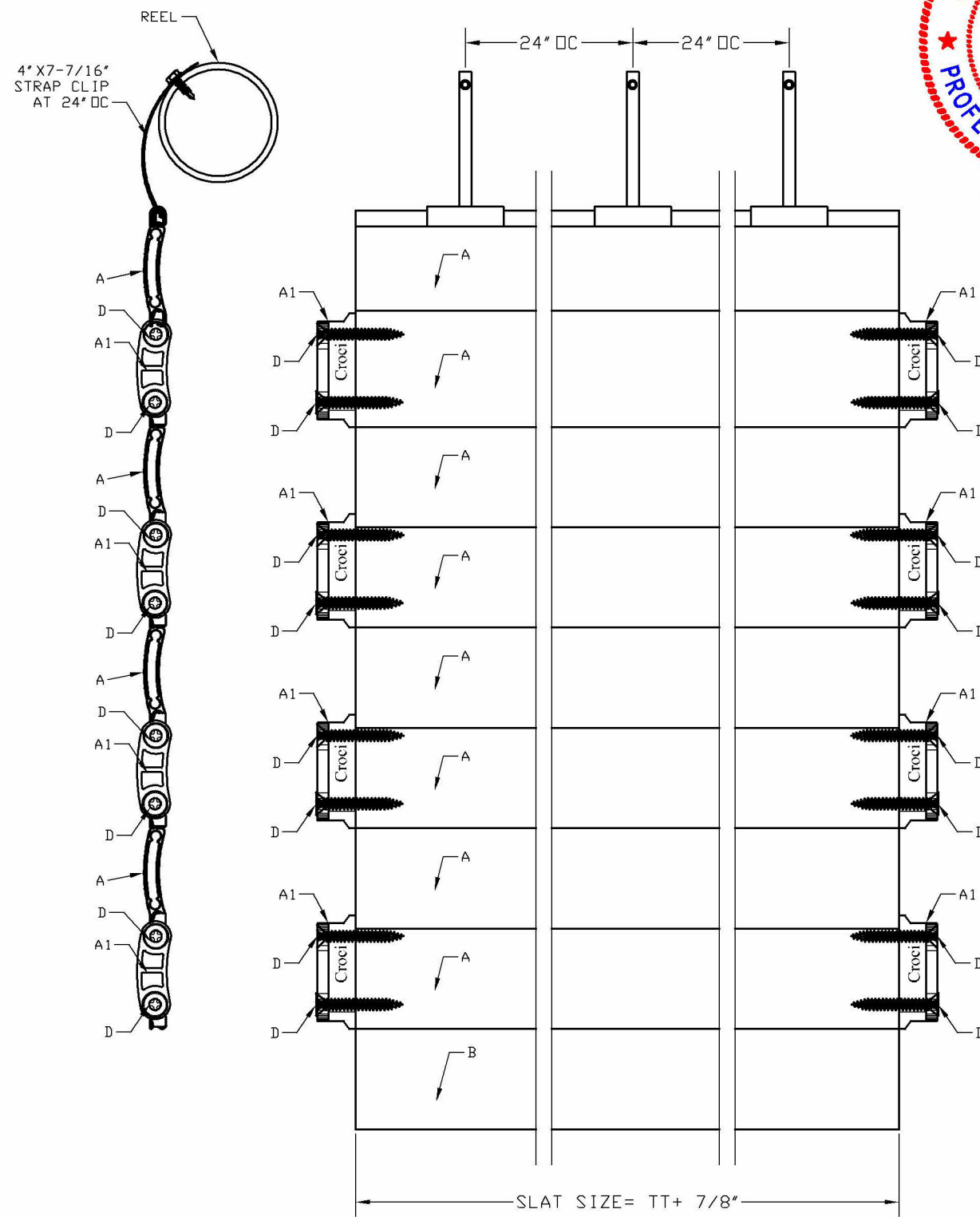

Pedro De Figueiredo
PE 52609
09/16/2023

THIS ITEM HAS BEEN DIGITALLY SIGNED AND SEALED BY PEDRO DE FIGUEIREDO ON THE DATE INDICATED HERE.



ENGINEERING SERVICES
CA 32459
9715 W. BROMWARD BLVD. 247
PLANTATION, FL 33324
PFMIF@AOL.COM

PRODUCT:
E544 SUP
ROLLING DOOR
LARGE & SMALL MISSILE
IMPACT RATED

MANUFACTURER:
CROCI
NORTH AMERICA
11600 ADELMO LANE FORT MYERS, FL 33966
TEL: (239) 278-3066 - FAX: (239) 278-5977
EMAIL: INFO@CROCIUSA.COM

SCALE:
NA

DATE:
09/16/2023

DRAWING #
23-164

SHEET
3 of 10

ENGINEER SEAL
PEDRO DE FIGUEIREDO
PE 52609

TYPICAL HORIZONTAL SECTIONS AND ANCHOR SCHEDULE

WALL MOUNT ANCHORAGE SPACING

LOAD Psf	FINISHED WIDTH (FW)																													
	64					82					94					109					124									
	A	A1	B	B1	C	D	A	A1	B	B1	C	D	A	A1	B	B1	C	D	A	A1	B	B1	C	D	A	A1	B	B1	C	D
30	6	6	6	6	6	6	6	6	6	6	6	6	6	6	6	6	6	6	6	6	6	6	6	6	6	6	6	6		
40	6	6	6	6	6	6	6	6	5	6	6	6	5	6	6	6	5	5	6	6	4	6	6	6	6	6	6	6		
45	6	6	6	6	6	6	6	6	5	6	6	6	5	6	3	6	4	5	6	6	3	6	5	6						
50	6	6	6	6	6	6	6	6	4	6	6	6	4	6					6	6	3	6	5	6						
55	6	6	5	6	6	6	6	6	4	6	6	6	4	6					6	6	3	6	4							
60	6	6	5	6	6	6	6	6	3	6	5	6	4	6					6	6	3	6	3							
65	6	6	4	6	6	6	5	6	3	6	5	5																		
70	6	6	4	6	6	6	5	6	3	6	4	5																		
80	6	6	3	6	6	6	4	6		6	4	4																		
90	6	6	3	6	5	6																								
100	6	6	3	6	5	6																								
105	6	6		6	5	6																								
110	5	6		6	5	6																								

ANCHOR SCHEDULE:

ANCHOR	DESCRIPTION	MATERIAL	EMBEDMENT	EDGE DISTANCE
A	1/4" X2-3/4" TAPCONS	MIN. 3192 psi CONCRETE	1-3/4"	2-1/2"
A1	5/16" X3" TAPCONS	MIN. 2899 psi CONCRETE	2 1/4"	3 1/8"
B	1/4" X2-3/4" TAPCONS	HOLLOW C-90 BLOCK	1 1/4"	2-1/2"
B1	5/16" X3" TAPCONS	GROUT FILLED C-90 BLOCK	2 1/4"	4"
C	1/4"-14X1" GRADE 5 SELF DRILLING SCREWS	MIN. 1/4" 6063-T6 ALUM. OR A36 3/16" STEEL		1/2" 3/8"
D	5/16" X3" TAPCONS	WOOD WITH G>= .55	2 1/4"	1-1/4"

INSET MOUNT ANCHORAGE SPACING

LOAD Psf	FINISHED WIDTH (FW)																											
	64					82					94					109					124							
	A	A1	B1	C	D	A	A1	B1	C	D	A	A1	B1	C	D	A	A1	B1	C	D	A	A1	B1	C	D			
30	6	6	6	6	6	6	6	6	6	6	4	6	6	6	6	4	6	6	6	6	5	6	6	6	6	6		
40	6	6	6	6	6	4	6	6	6	6	3	4	5	5	4	3	5	6	6	5	4	6	6	6	6	6		
45	6	6	6	6	6	3	5	6	6	5		4	4	5	4	3	5	6	6	5								
50	6	6	6	6	6	3	5	6	6	5		4	4	3	3	4	5	5	4									
55	5	6	6	6	6	3	4	5	5	4			4	4	3													
60	5	6	6	6	6	3	4	5	5	4				3	3													
65	4	6	6	6	6		4	4	4	4																		
70	4	6	6	6	5			4	4	3																		
80	3	6	6	6	5			4	4	3																		
90	3	5	6	6	4																							
100	3	5	5	5	4																							
105	3	4	5	5	4																							
110	3	4	5	5	3																							

ANCHOR TYPE B	
LOAD Psf	FINISHED WIDTH (FW)
30	6
40	3
45	3

THIS ITEM HAS BEEN DIGITALLY SIGNED AND SEALED BY PEDRO DE FIGUEIREDO ON THE DATE INDICATED HERE.

SEE WALL MOUNT TABLE

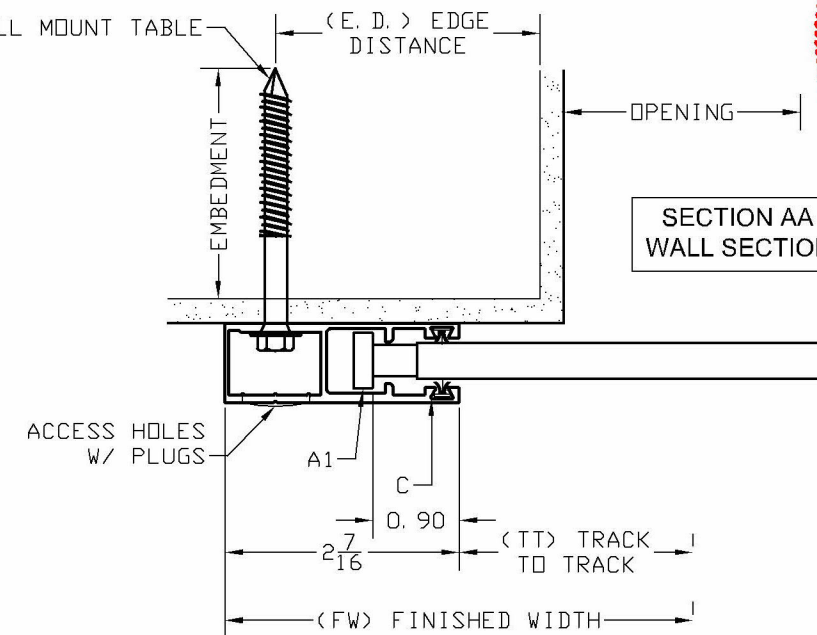

SECTION AA
WALL SECTION

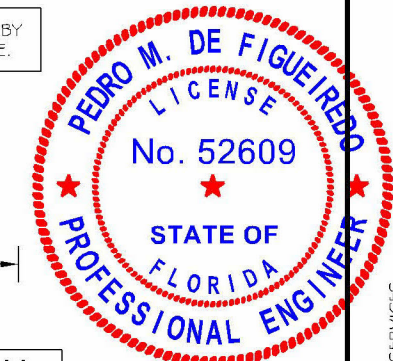

Pedro De Figueiredo
PE 52609
09/16/2023

ENGINEERING SERVICES
CA. 32459
9715 W. BROWARD BLVD. 247
PLANTATION, FL 33324
PFMIF@AOL.COM



PRODUCT:
E544 SUP
ROLLING DOOR
LARGE & SMALL MISSILE
IMPACT RATED

MANUFACTURER:
CROCI
NORTH AMERICA
11600 ADELMO LANE FORT MYERS, FL 33966
TEL: (239) 278-3066 - FAX: (239) 278-5977
EMAIL: INFO@CROCIUSA.COM

SCALE:
NA
DATE:
09/16/2023
DRAWING #
23-164
SHEET
4 of 10

SECTION BB
INSET MOUNT

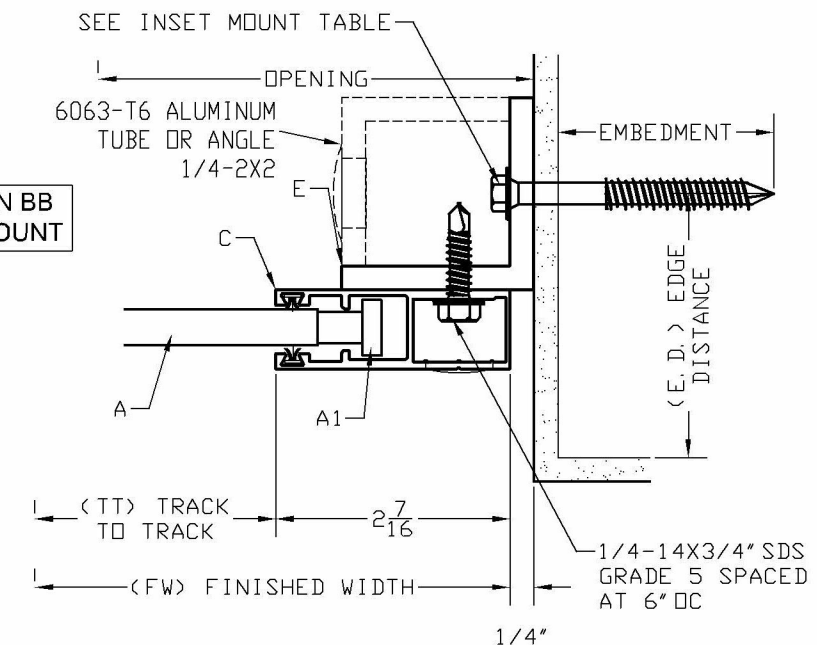

BUILT-OUT MOUNT ANCHORAGE SPACING

LOAD Psf	FINISHED WIDTH (FW)																								
	64					82					94					109					124				
	A	A1	B1	C	D	A	A1	B1	C	D	A	A1	B1	C	D	A	A1	B1	C	D	A	A1	B1	C	D
30	6	6	6	6	6	5	6	6	6	6	3	5	6	6	4	4	6	6	6	5	4	6	6	6	6
40	6	6	6	6	6	3	5	5	6	4		4	4	4	3	3	5	6	6	4	4	6	6	6	5
45	6	6	6	6	6	3	5	5	5	4			4	4		3	5	5	5	4					
50	6	6	6	6	6		4	5	5	3					3	4	5	5	3						
55	6	6	6	6	6		4	4	4	3					3										
60	6	6	6	6	6		4	4	4	3					3										
65	5	6	6	6	6			4	4																
70	5	6	6	6	6																				
80	4	6	6	6	5									3											
90	4	6	6	6	5																				
100	3	6	6	6	4																				
105	3	5	6	6	4																				
110	3	5	6	6	4																				

ANCHOR TYPE B	
LOAD Psf	FINISHED WIDTH (FW)
64	6
30	6
40	4
45	3
50	3

ANCHOR SCHEDULE:

ANCHOR	DESCRIPTION	MATERIAL	EMBEDMENT	EDGE DISTANCE
A	1/4" X2-3/4" TAPCONS	MIN. 3192 psi CONCRETE	1-3/4"	2-1/2"
A1	5/16" X3" TAPCONS	MIN. 2899 psi CONCRETE	2 1/4"	3 1/8"
B	1/4" X2-3/4" TAPCONS	HOLLOW C-90 BLOCK	1 1/4"	2-1/2"
B1	5/16" X3" TAPCONS	GROUT FILLED C-90 BLOCK	2 1/4"	4"
C	1/4"-14X1" GRADE 5 SELF DRILLING SCREWS	MIN. 1/4" 6063-T6 ALUM. OR A36 3/16" STEEL		1/2" 3/8"
D	5/16" X3" TAPCONS	WOOD WITH G>= .55	2 1/4"	1-1/4"

ALTERNATE INSET MOUNT ANCHORAGE SPACING

LOAD Psf	ANCHORS A, A1, B1, C, D				
	FINISHED WIDTH (FW)				
	64	82	94	109	124
30	6	6	6	6	6
40	6	6	6	6	6
45	6	6	6	6	
50	6	6	6	6	
55	6	6	6		
60	6	6	6		
65	6	6			
70	6	6			
80	6	6			
90	6				
100	6				
105	6				
110	6				

LOAD Psf	ANCHOR B				
	FINISHED WIDTH (FW)				
	64	82	94	109	124
30	6	6	6	6	6
40	6	6	4	5	6
45	6	5	4	5	
50	6	5	3	4	
55	6	4	3		
60	6	4	3		
65	6	4			
70	6	3			
80	6	3			
90	5				
100	5				
105	4				
110	4				

SEE BUILT-OUT MOUNT TABLE

SECTION GG
BUILT-OUT SECTION

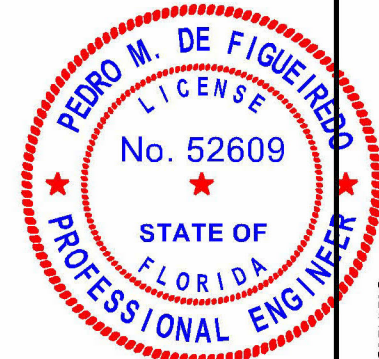
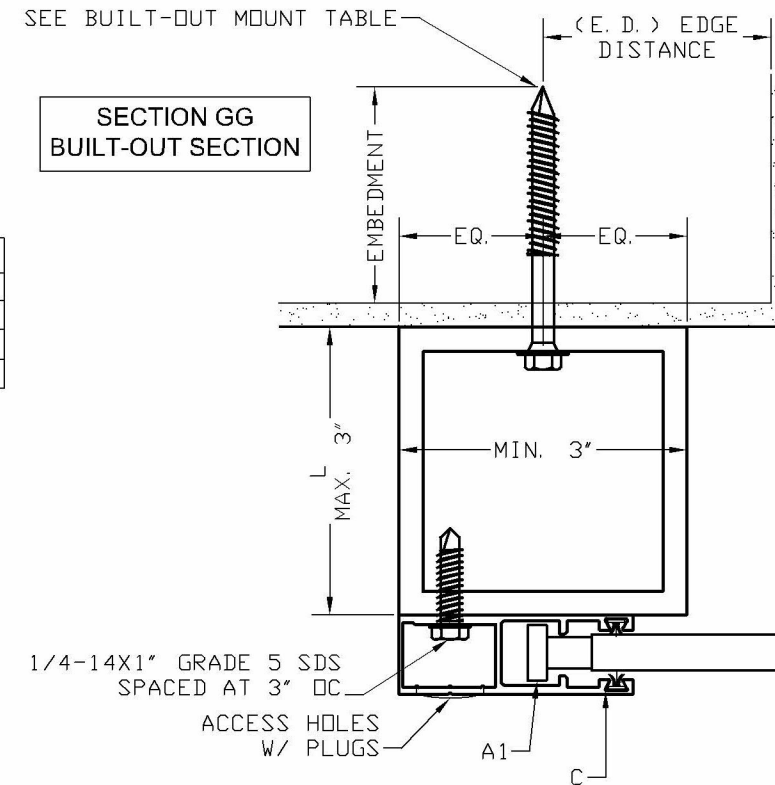

Pedro De Figueiredo
PE 52609
09/16/2023

THIS ITEM HAS BEEN DIGITALLY SIGNED AND SEALED BY PEDRO DE FIGUEIREDO ON THE DATE INDICATED HERE.



PRODUCT:
E544 SUP
ROLLING DOOR
LARGE & SMALL MISSILE
IMPACT RATED

MANUFACTURER:
CROCI
NORTH AMERICA
11600 ADELMO LANE FORT MYERS, FL 33966
TEL.: (239) 278-3066 - FAX: (239) 278-5977
EMAIL: INFO@CROCIUSA.COM

SCALE:
NA
DATE:
09/16/2023
DRAWING #
23-164
SHEET
5 of 10

SECTION BB1
ALTERNATE
INSET MOUNT

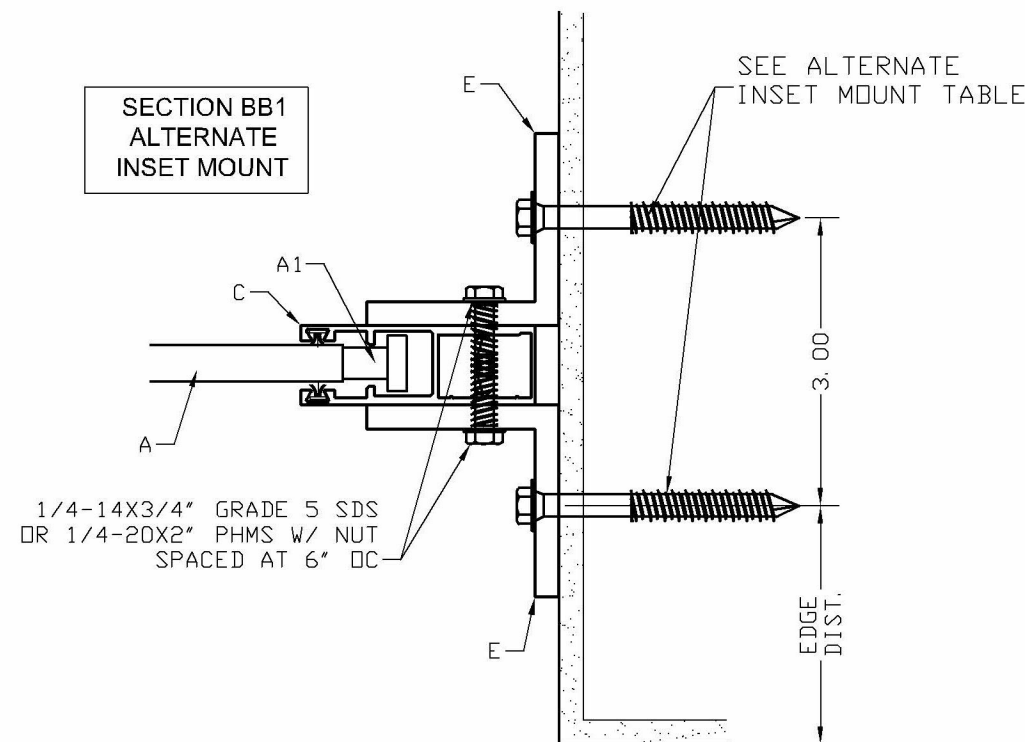

ENGINEER SEAL
PEDRO DE FIGUEIREDO
PE 52609

ENGINEERING SERVICES
CA 32459
9715 W. BROWARD BLVD. 247
PLANTATION, FL 33324
PFMIF@AOL.COM

EQUALLY SPACED MULLIONS SELECTION

THIS ITEM HAS BEEN DIGITALLY SIGNED AND SEALED BY PEDRO DE FIGUEIREDO ON THE DATE INDICATED HERE.

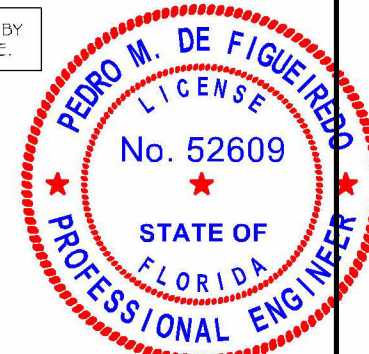

Pedro De Figueiredo
PE 52609
09/16/2023

ENGINEERING SERVICES
CA 32459
9715 W. BROMWAD BLVD. 247
PLANTATION, FL 33324
PFMIF@AOL.COM

ENGINEER SEAL
PEDRO DE FIGUEIREDO
PE 52609

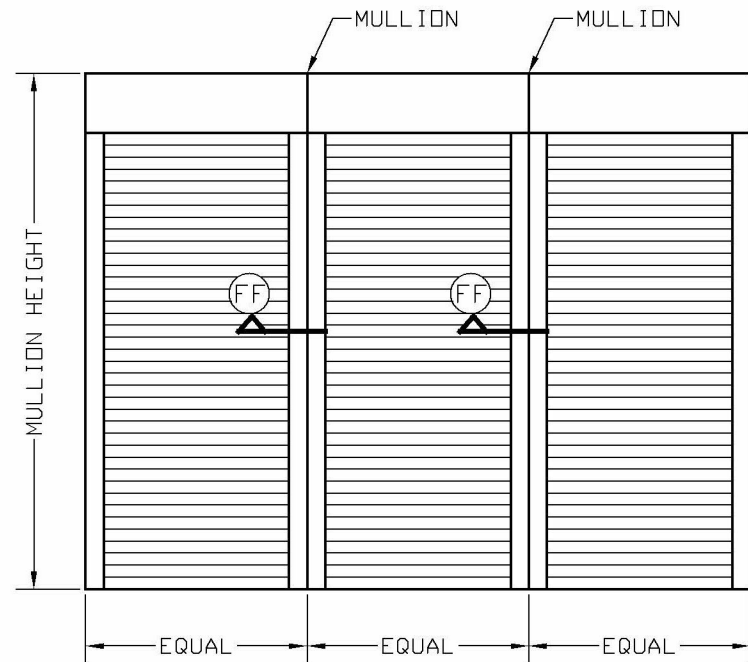

TABLE 2 - EQUAL SPACED MULLION DESIGNED PRESSURES (PSF)

DOOR MODULE	MULLION TYPE & MAX. HEIGHT								
	1/4-4x6			1/4-4x4			1/4-3x3		
124	39	40	40	25	35	40	13	19	29
109	44	50	50	29	39	50	15	22	33
94	51	60	60	33	46	60	18	26	38
82	59	80	80	38	53	75	20	29	44
64	76	110	110	49	67	96	26	38	57

MULLION MAX. HEIGHT

MAXIMUM PRESSURE IN PSF

NOTE: TABLE 2 IS APPLICABLE ONLY FOR EQUAL DOOR MODULES

SECTION FF
EQUALLY SPACED MULLIONS
WALL MOUNT TRACK

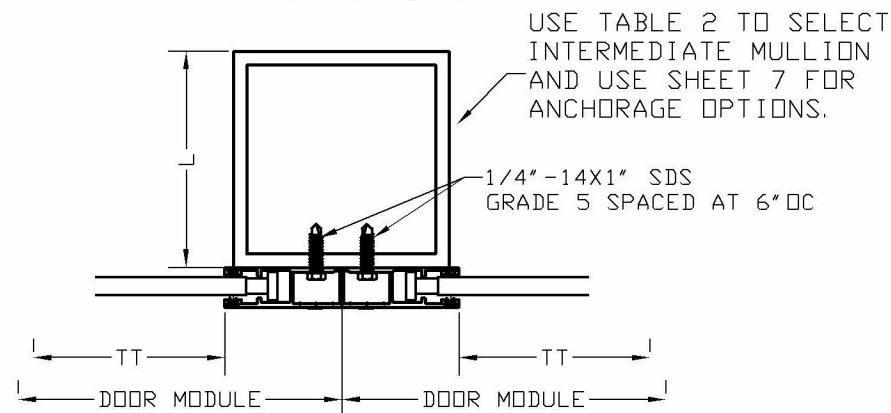

SECTION FF
EQUALLY SPACED MULLIONS
INSET MOUNT TRACK

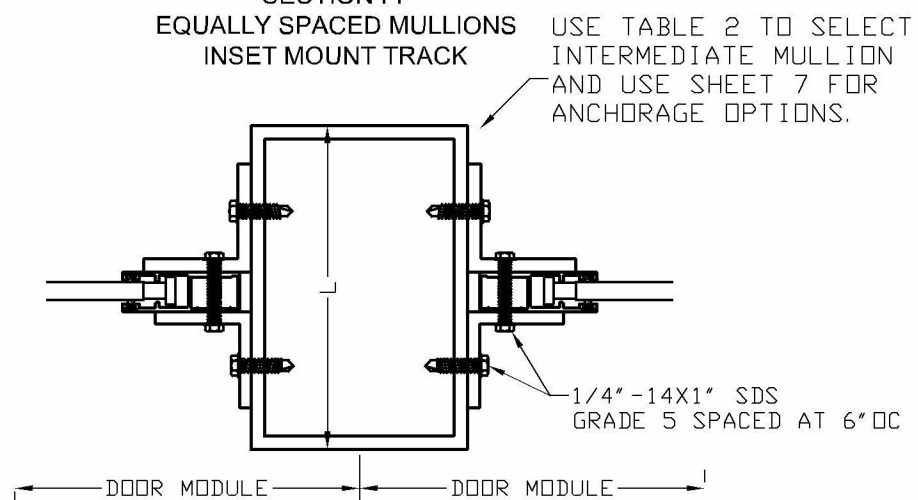

MULLIONS SECTIONS

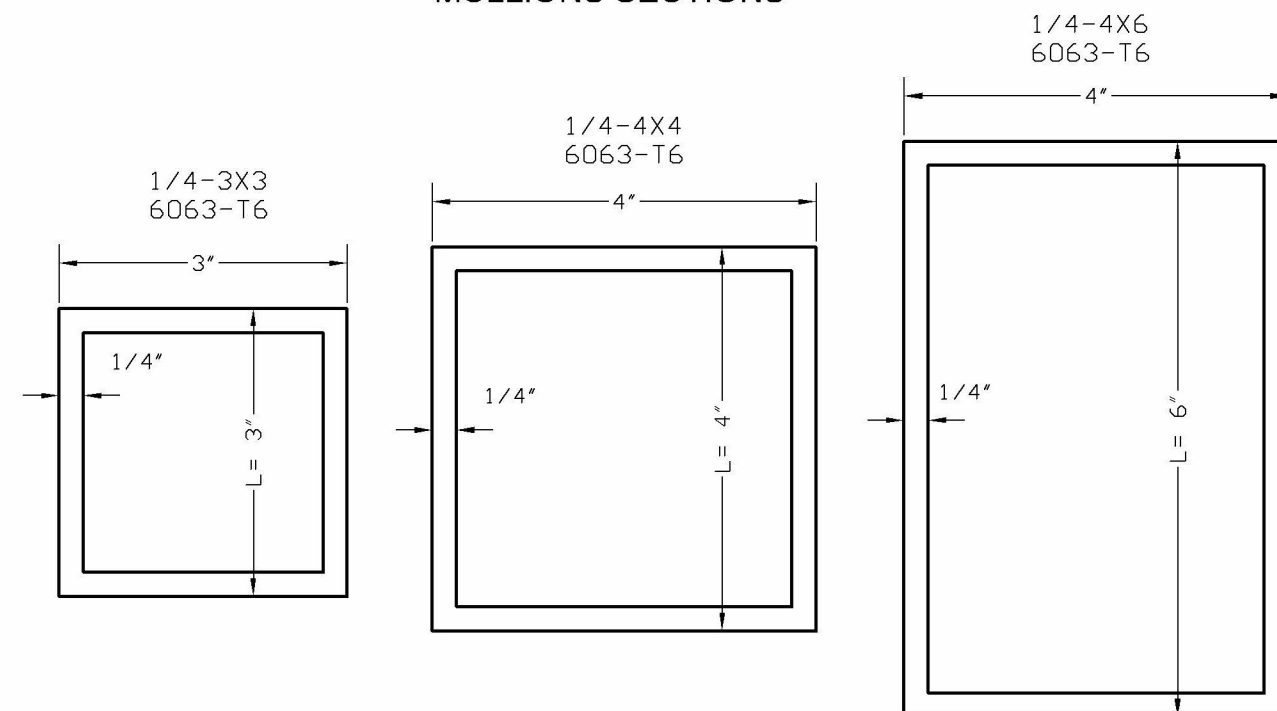

PRODUCT:
E544 SUP
ROLLING DOOR
LARGE & SMALL MISSILE
IMPACT RATED

MANUFACTURER:
CROCI
NORTH AMERICA
11600 ADELMO LANE FORT MYERS, FL 33966
TEL: (239) 278-3066 - FAX: (239) 278-5977
EMAIL: INFO@CROCIUSA.COM

SCALE:

NA

DATE:

09/16/2023

DRAWING #

23-164

SHEET

6 of 10

EQUALLY SPACED MULLIONS WALL AND FLOOR CONNECTIONS

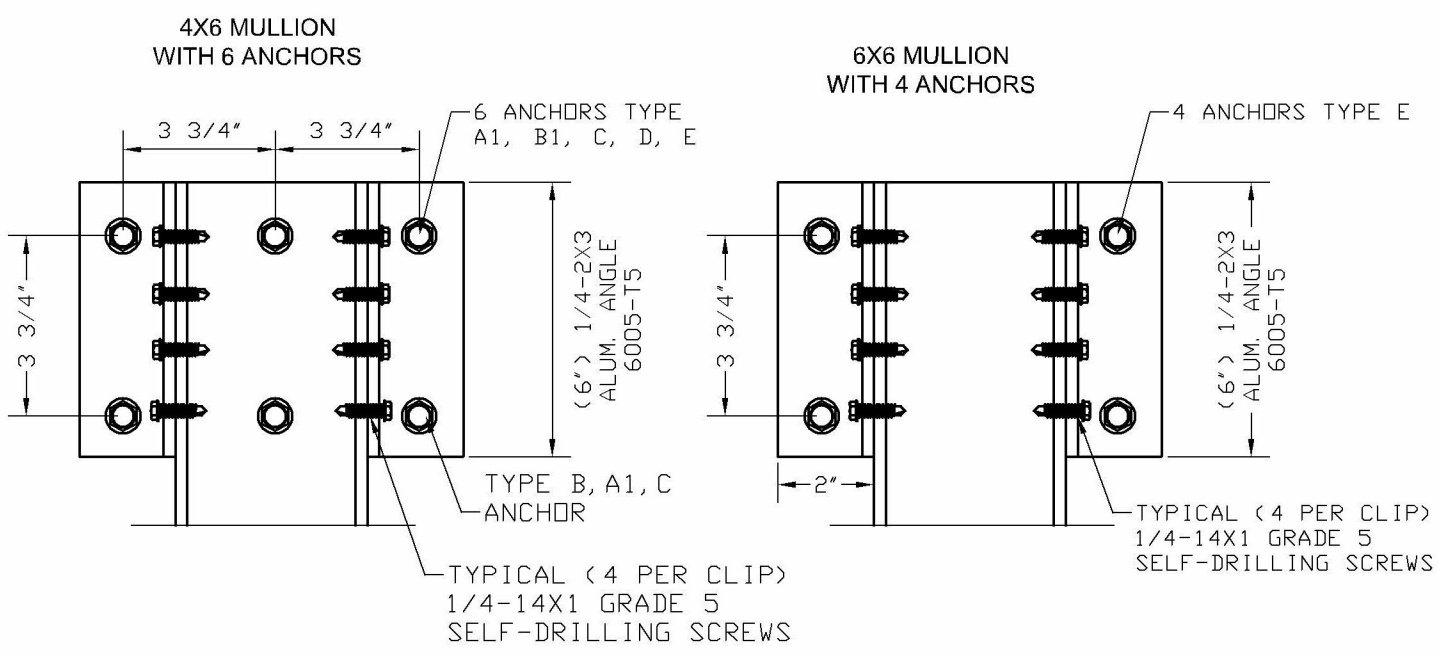
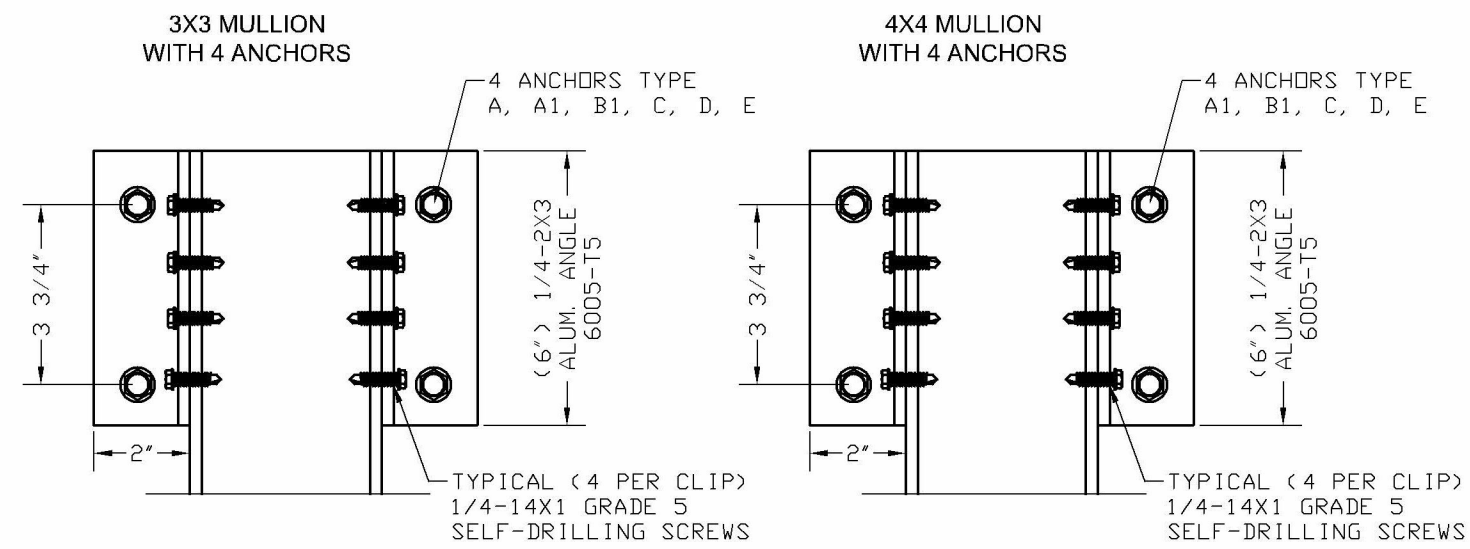

ANCHORAGE DESIGN FOR MAXIMUM LOADS FROM TABLE 2

ANCHOR SCHEDULE:				
ANCHOR	DESCRIPTION	MATERIAL	EMBEDMENT	EDGE DISTANCE
A	1/4" X2-3/4" TAPCONS	MIN. 3192 psi CONCRETE	1-3/4"	2-1/2"
A1	5/16" X3" TAPCONS	MIN. 2899 psi CONCRETE	2 1/4"	3 1/8"
B	1/4" X2-3/4" TAPCONS	HOLLOW C-90 BLOCK	1 1/4"	2-1/2"
B1	5/16" X3" TAPCONS	GROUT FILLED C-90 BLOCK	2 1/4"	4"
C	1/4"-14X1" GRADE 5 SELF DRILLING SCREWS	MIN. 1/4" 6063-T6 ALUM. OR A36 3/16" STEEL		1/2" 3/8"
D	5/16" X3" TAPCONS	WOOD WITH G>= .55	2 1/4"	1-1/4"
E	3/8" X4" WEDGE BOLTS	MIN. 3000 psi CONCRETE	3 1/2"	4 1/2"

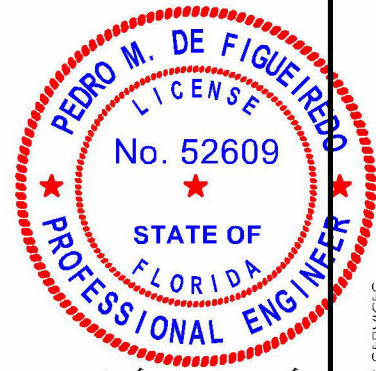
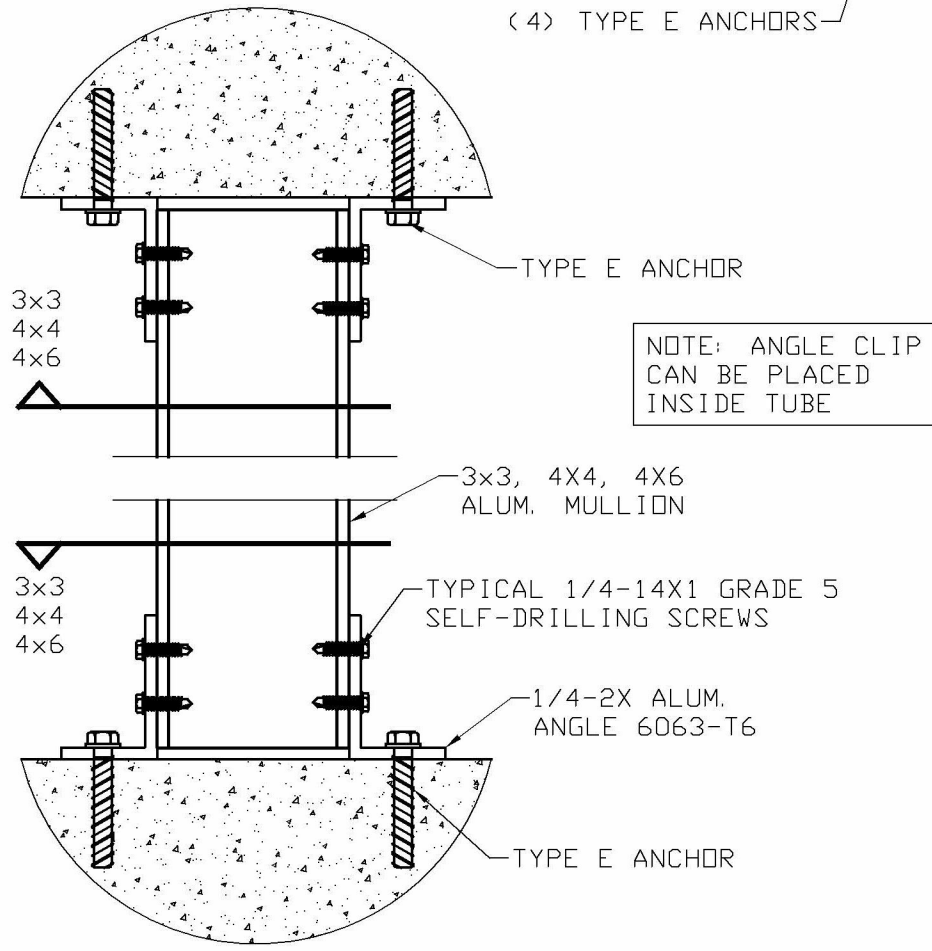
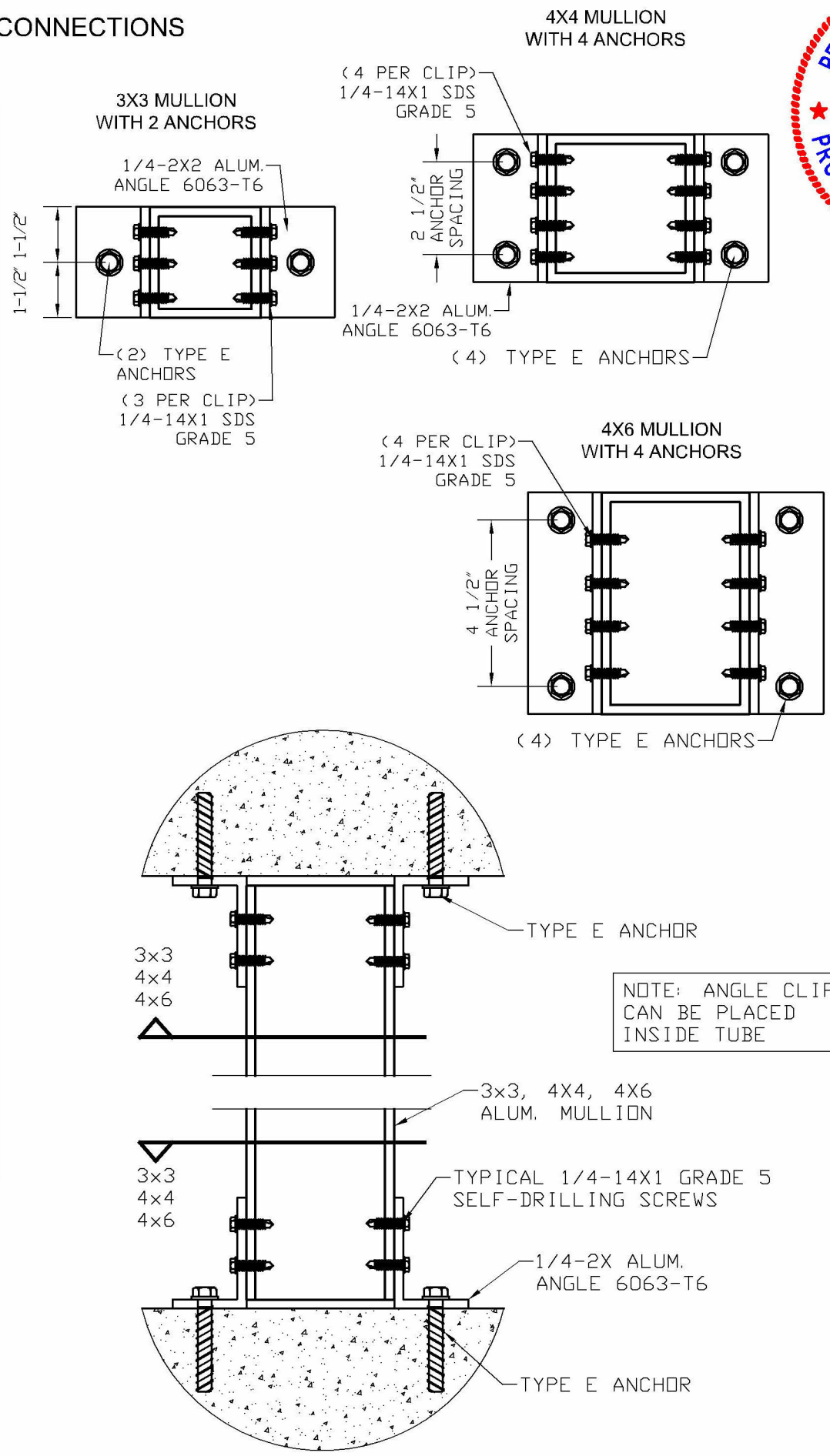

Pedro De Figueiredo
PE 52609
09/16/2023

THIS ITEM HAS BEEN DIGITALLY SIGNED AND SEALED BY PEDRO DE FIGUEIREDO ON THE DATE INDICATED HERE.



PRODUCT:
E544 SUP
ROLLING DOOR
LARGE & SMALL MISSILE
IMPACT RATED

MANUFACTURER:
CROCI
NORTH AMERICA
11600 ADELMO LANE FORT MYERS, FL 33966
TEL: (239) 278-3066 - FAX: (239) 278-5977
EMAIL: INFO@CROCIUSA.COM

SCALE:
NA
DATE:
09/16/2023
DRAWING #
23-164
SHEET
7 of 10

ENGINEERING SERVICES
CA 32459
9715 W. BROMFORD BLVD. 247
PLANTATION, FL 33324
PFMIF@AOL.COM

ENGINEER SEAL
PEDRO DE FIGUEIREDO
PE 52609

UNEQUALLY SPACED MULLIONS SELECTION

THIS ITEM HAS BEEN DIGITALLY SIGNED AND SEALED BY PEDRO DE FIGUEIREDO ON THE DATE INDICATED HERE.

TABLE 3 - MAXIMUM MULLION HEIGHT FOR UNEQUAL SPACED MULLIONS AND END MULLIONS

Pd (Psf)	SM1 (in)	SM2 (in)	MH (in)	
40	124	0-<64	132	END MULL
		64	132	INT. MULL
		82	132	
		94	120	
		109	120	
50	109	0-<64	114	END MULL
		64	102	INT. MULL
		82	81	
		94	96	
		60	94	0-<64
60	94	64	96	INT. MULL
		82	120	
		80	82	0-<64
80	82	64	102	INT. MULL
		110	64	0

NOTES:

- 1- TABLE IS APPLICABLE ONLY FOR UNEQUAL DOOR MODULES AND END MULLION.
- 2- USE 1/4-4X6 MULLION AS PER SECTIONS EE, HH
- 3- PD= MAXIMUM DESIGNED PRESSURE IN PSF
- 4- THE MAXIMUM END MULLION SIZES (SM2=0) ARE FOUND WHEN SM2=0
- 5- SPECIFIC CONDITIONS NOT INCLUDED HERE IN ARE TO BE ADDRESSED WITH SITE SPECIFIC PROVIDED BY A PROFESSIONAL ENGINEER.

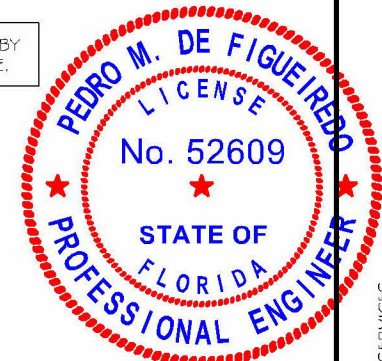
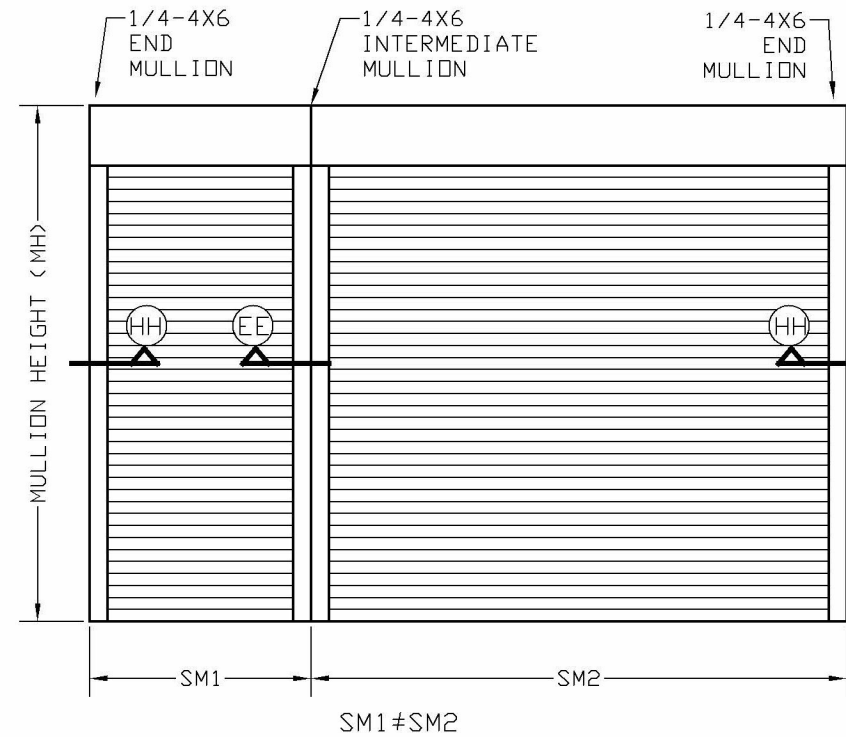

Pedro De Figueiredo
PE 52609
09/16/2023

ENGINEERING SERVICES
CA 32459
9715 W. BROWARD BLVD. 247
PLANTATION, FL 33324
PPMIF@AOL.COM



PRODUCT:
E544 SUP
ROLLING DOOR
LARGE & SMALL MISSILE
IMPACT RATED

MANUFACTURER:
CROCI
NORTH AMERICA
11600 ADELMO LANE FORT MYERS, FL 33966
TEL: (239) 278-3066 - FAX: (239) 278-5977
EMAIL: INFO@CROCIUSA.COM

SCALE:
NA
DATE:
09/16/2023
DRAWING #
23-164
SHEET
8 of 10

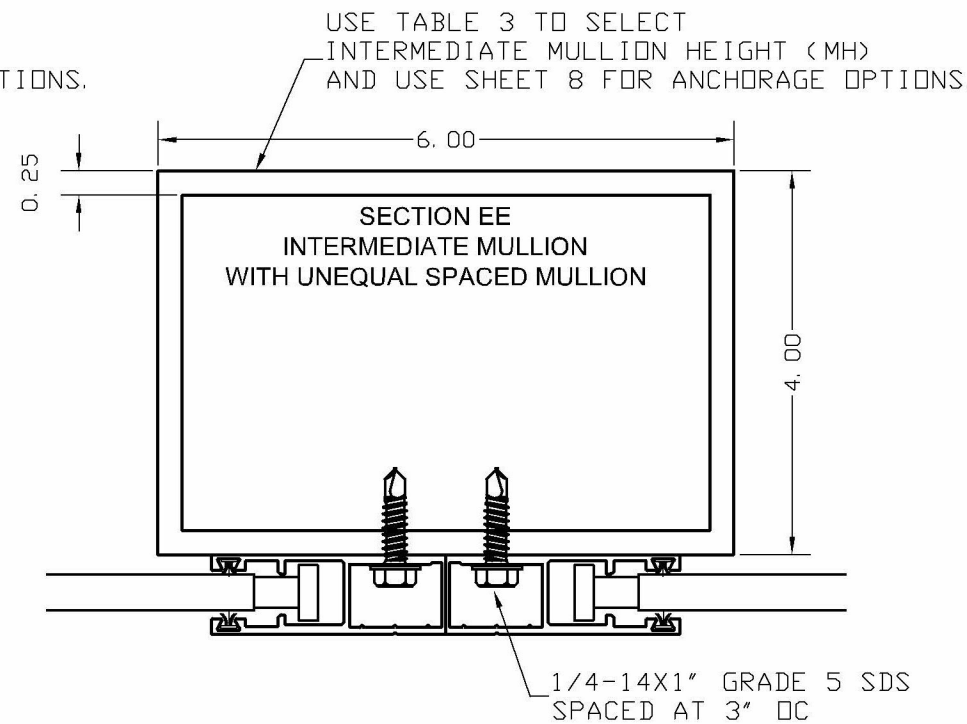
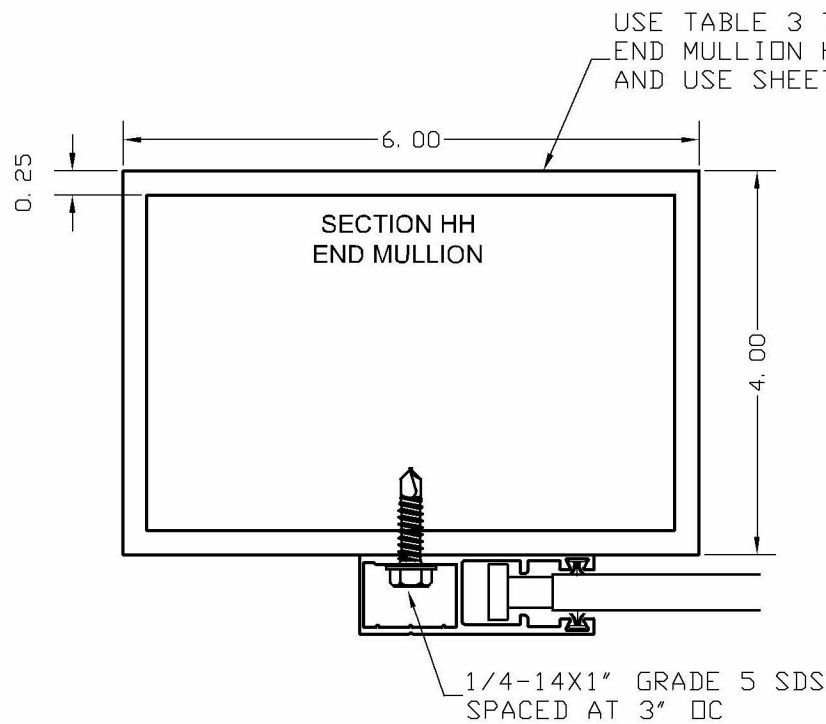

UNEQUAL SPACED MULLIONS AND END MULLIONS
WALL AND FLOOR CONNECTIONS

WALL MOUNT END MULLION

WALL MOUNT INTERMEDIATE MULLION

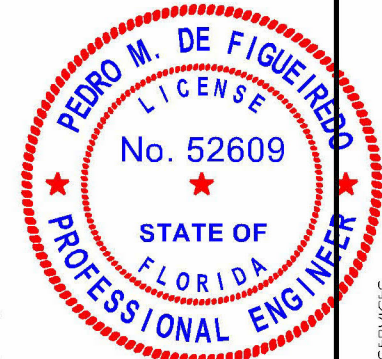
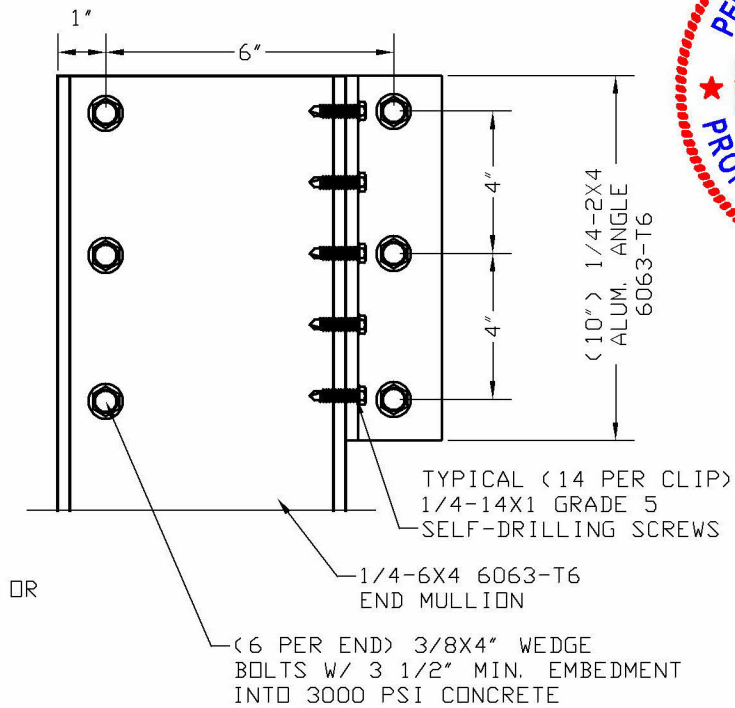
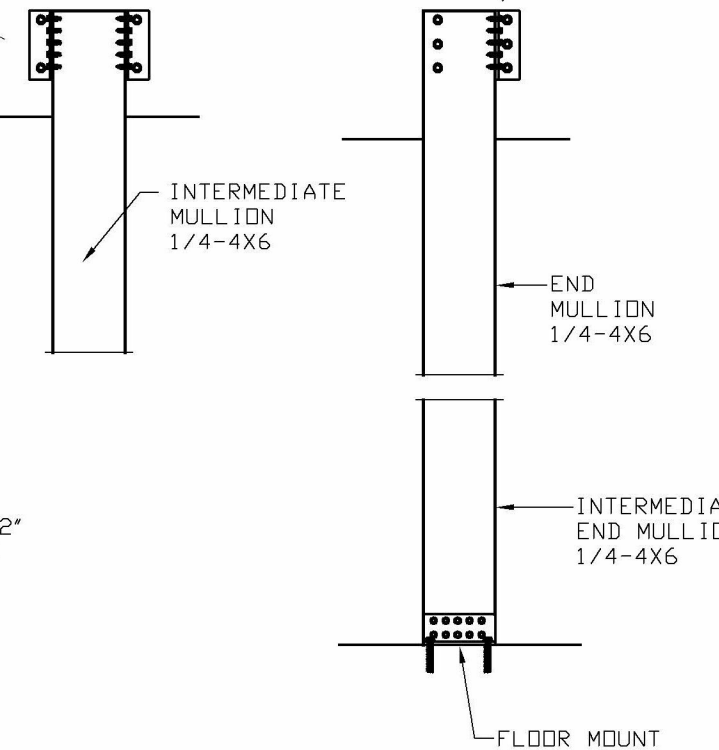
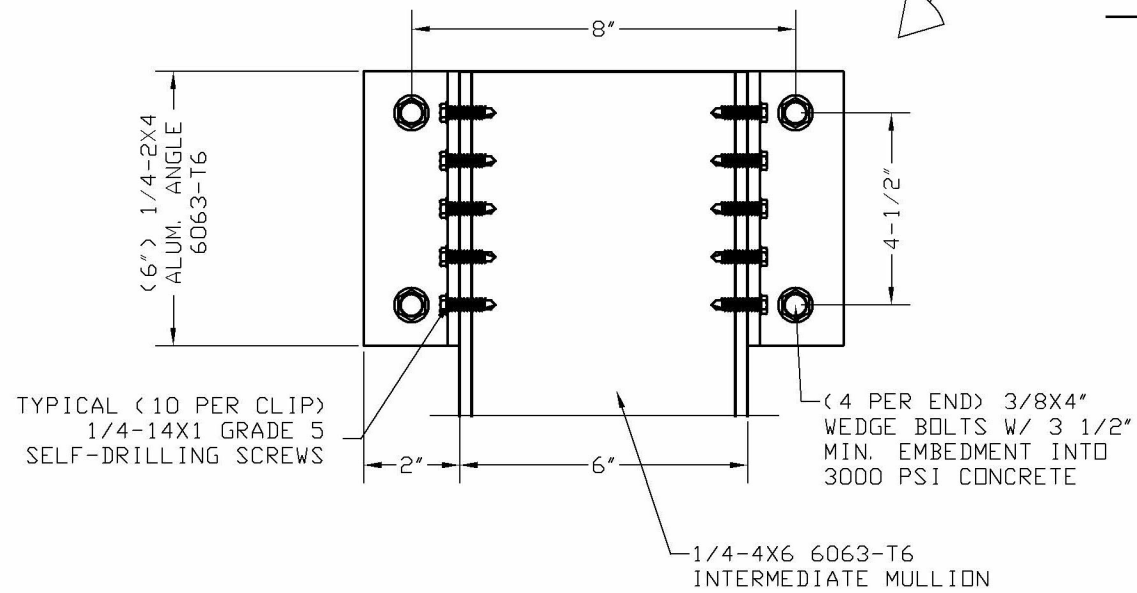

Pedro De Figueiredo
PE 52609
09/16/2023

THIS ITEM HAS BEEN DIGITALLY SIGNED AND SEALED BY
PEDRO DE FIGUEIREDO ON THE DATE INDICATED HERE.



ENGINEERING SERVICES
CA 32459
9715 W. BROWARD BLVD. 247
PLANTATION, FL 33324
PFMIF@AOL.COM

ENGINEER SEAL
PEDRO DE FIGUEIREDO
PE 52609

FLOOR MOUNT INTERMEDIATE & END MULLION

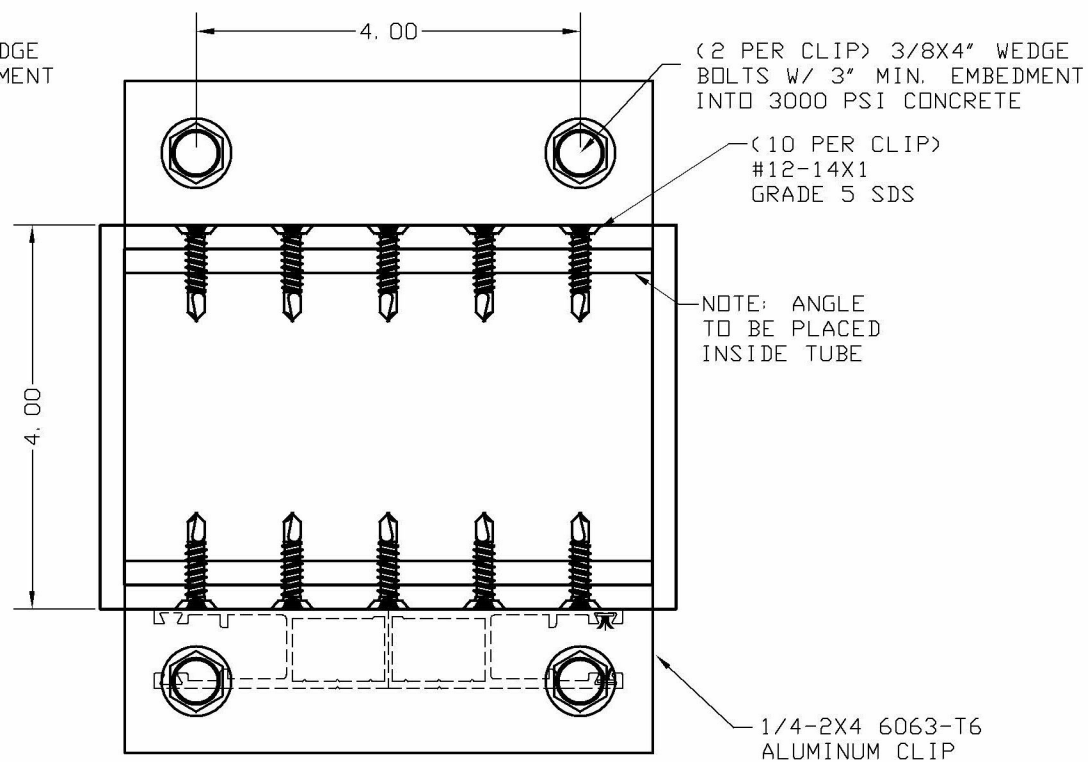
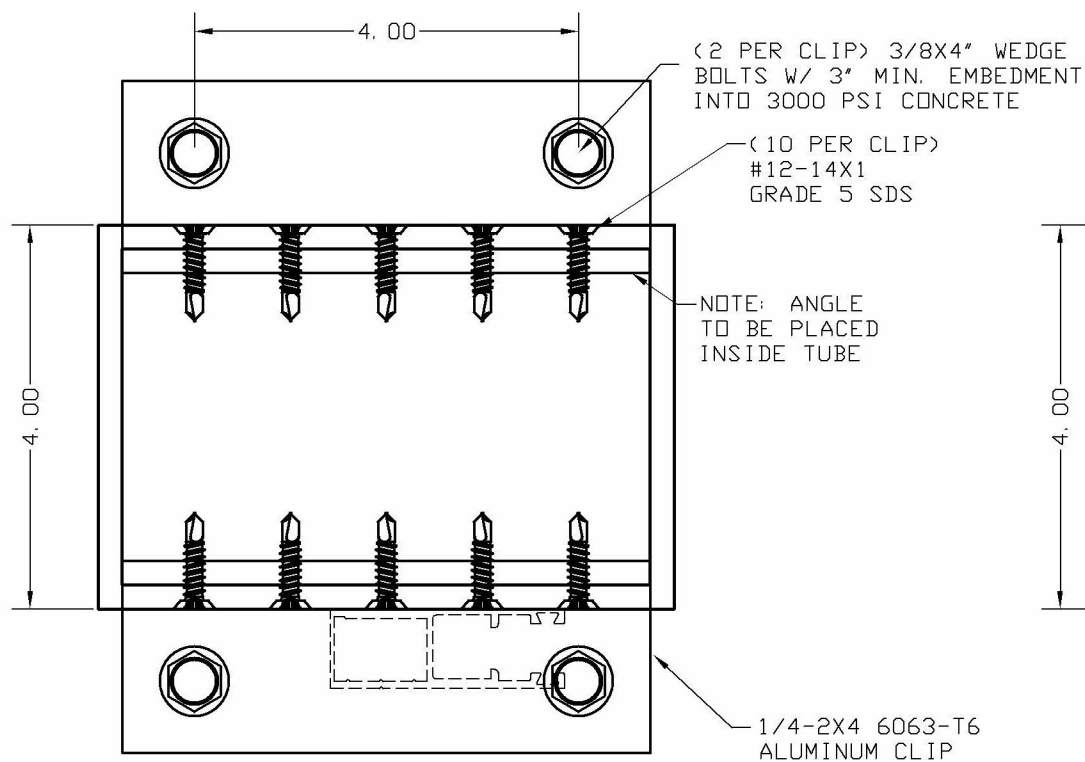

PRODUCT:
E544 SUP
ROLLING DOOR
LARGE & SMALL MISSILE
IMPACT RATED

MANUFACTURER:
CROCI
NORTH AMERICA
11600 ADELMO LANE FORT MYERS, FL 33966
TEL: (239) 278-3066 - FAX: (239) 278-5977
EMAIL: INFO@CROCIUSA.COM

SCALE:
NA
DATE:
09/16/2023
DRAWING #
23-164
SHEET
9 of 10

HOOD ASSEMBLY

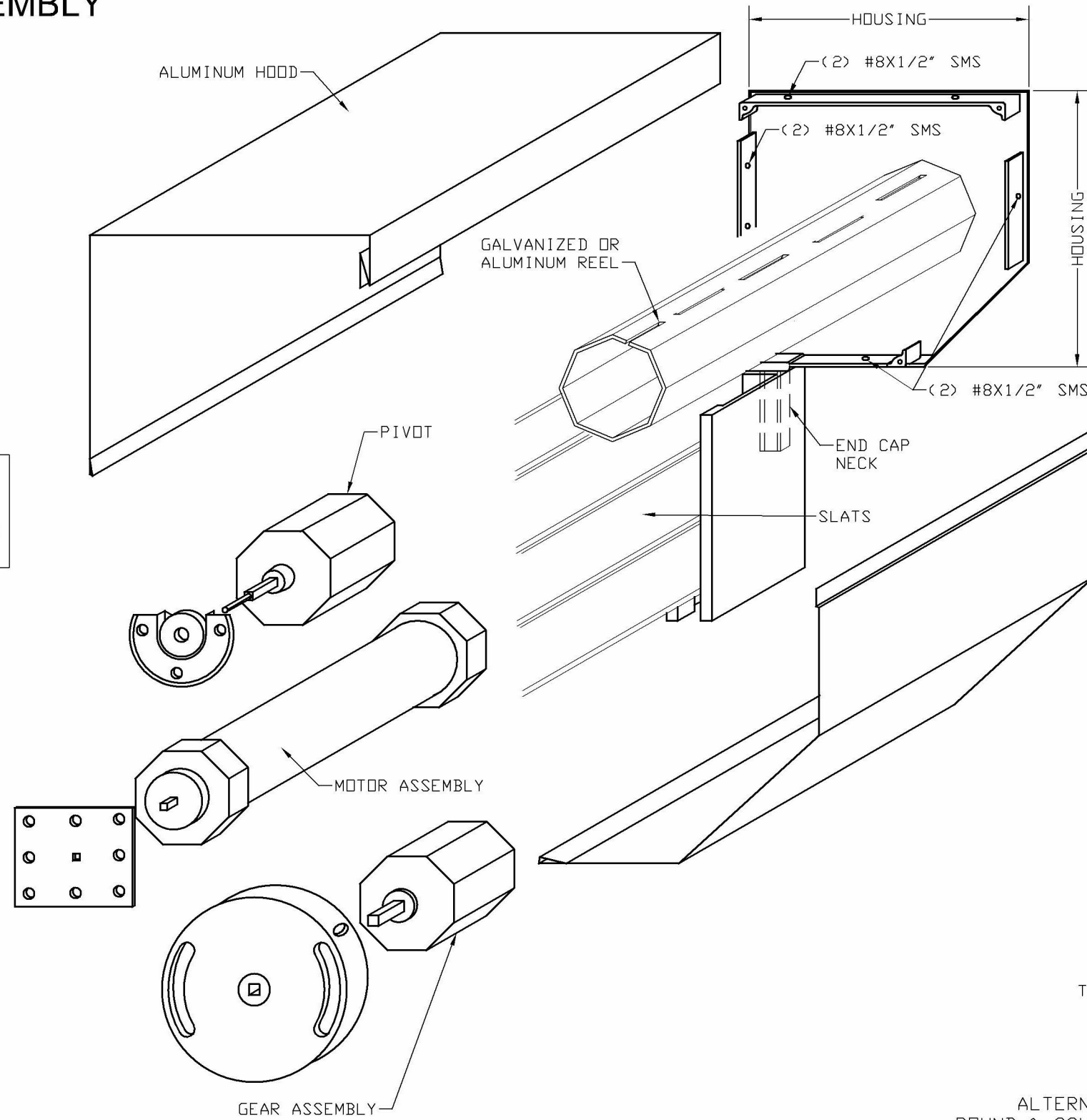

NOTE: THE ROLL-UP MECHANISM (GEARS, MOTORS, SUPPORTING END PLATES) ARE NOT PART OF THIS APPROVAL. MANUFACTURER IS RESPONSIBLE TO SPECIFY THESE COMPONENTS FOR PROPER DOOR OPERATION.

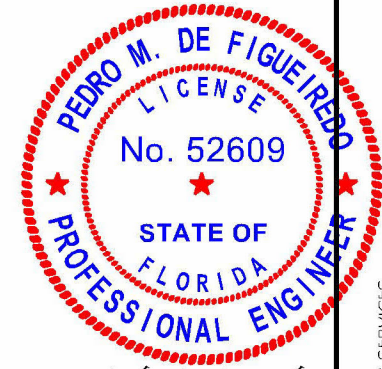

Pedro De Figueiredo
PE 52609
09/16/2023

THIS ITEM HAS BEEN DIGITALLY SIGNED AND SEALED BY PEDRO DE FIGUEIREDO ON THE DATE INDICATED HERE.



PRODUCT:
E544 SUP
ROLLING DOOR
LARGE & SMALL MISSILE
IMPACT RATED

MANUFACTURER:
CROCI
NORTH AMERICA
11600 ADELMO LANE FORT MYERS, FL 33966
TEL: (239) 278-3066 - FAX: (239) 278-5977
EMAIL: INFO@CROCIUSA.COM

SCALE:
NA

DATE:
09/16/2023

DRAWING #
23-164

SHEET
10 of 10

ENGINEERING SERVICES
CA 32459
9715 W. BROWARD BLVD. 247
PLANTATION, FL 33324
PPMIF@AOL.COM
ENGINEER SEAL
PEDRO DE FIGUEIREDO
PE 52609